

Fume Generation in Al-Mg Alloy Welding with AC-pulsed GMA Welding Method†

Masao USHIO*, Kazuhiko NAKATA**, Manabu TANAKA***, Hongjun TONG**** and Tsuneo MITA*****

Abstract

A novel AC-pulsed GMA inverter welder has been developed to reduce the weld fumes, generated from the overheated droplets of filler metal wire, which contain high vapor pressure alloying elements. In the fume collection experiment with our new welder, the effects of alloying components both in solid wire and base metal on fume generation have been studied with different combinations of welding materials. We have found that Mg in the wire is the main fume generation source in DCEP-pulsed GMA welding of an Al-Mg alloy, and our AC-pulsed GMA inverter welder can suppress its effect satisfactorily. The effects of welding parameters (welding current, arc voltage, etc.) on fume generation have also been investigated. X-ray diffraction has been used to identify the compositions of fumes collected under different welding conditions. After observing droplet transfer with an ultra-high speed video camera, fume generating phenomena and mechanisms of fume suppression are discussed.

KEY WORDS: (Weld Fumes) (AC Inverter Welder) (Pulsed GMAW) (Al-Mg Welding)

1. Introduction

Fumes are generated in all arc welding processes, and they have adverse health effects on welding operators. Although numerous studies of fume generation in arc welding have been made, there are few ideal means to suppress fume generation. The practical solution to the fume problem is still at the stage of using a fume extraction system and a mask, which are passive and inconvenient. Therefore, their application is limited. It was reported recently that a pulsed, rectangular-wave GMA inverter welder is able to reduce fume generation by over 50% compared to conventional welding¹⁾. But we can not expect that this kind of welder has the same efficacy when the filler metal wire contains high vapor pressure elements such as Mg, Zn and Li. In GMA welding, the presence of Mg in 5000 series filler metal wire causes a breakdown in the stability of metal transfer and explosive phenomenon to occur during metal transfer, which in return results in a high level of spatter formation²⁾. We suppose that this is also a main source of fume generation in the welding.

In the present work, we have found it difficult to realize a completely smooth metal transfer in Al-Mg

alloy welding, even with a DCEP-pulsed inverter welder. Smooth metal transferring is achieved with our AC-pulsed GMA inverter welder by reducing the evaporation of Mg in the droplets and eliminating droplet explosion. As a result, fume generation is successfully suppressed.

2. Experimental Procedures

2.1 Welding power source

Figure 1 shows the welding power source that we have developed and used in the experiment. It consists of two inverters and has a constant voltage. The primary inverter controls the instantaneous value of output voltage whereas the secondary inverter acts only as a switcher to change the polarity of output voltage for AC-pulsed GMA welding.

Figure 2 is a schematic diagram to explain the concept of AC pulse waveform control. In the pulse duration (T_{ep}) the output voltage is rapidly increased to V_{ep} so that the current rises quickly over the threshold current for a transition to spray transfer mode. It is kept at V_{ep} for a duration of T_p and then is reduced to V_r within time T_r . As soon as the output voltage decreases

† Received on July 11, 1994

* Professor

** Associate Professor

*** Research Associate

**** Graduate Student

***** Research Engineer, Hitach Seiko Ltd.

Transactions of JWRI is published by Welding Research Institute of Osaka University, Ibaraki, Osaka 567, Japan.

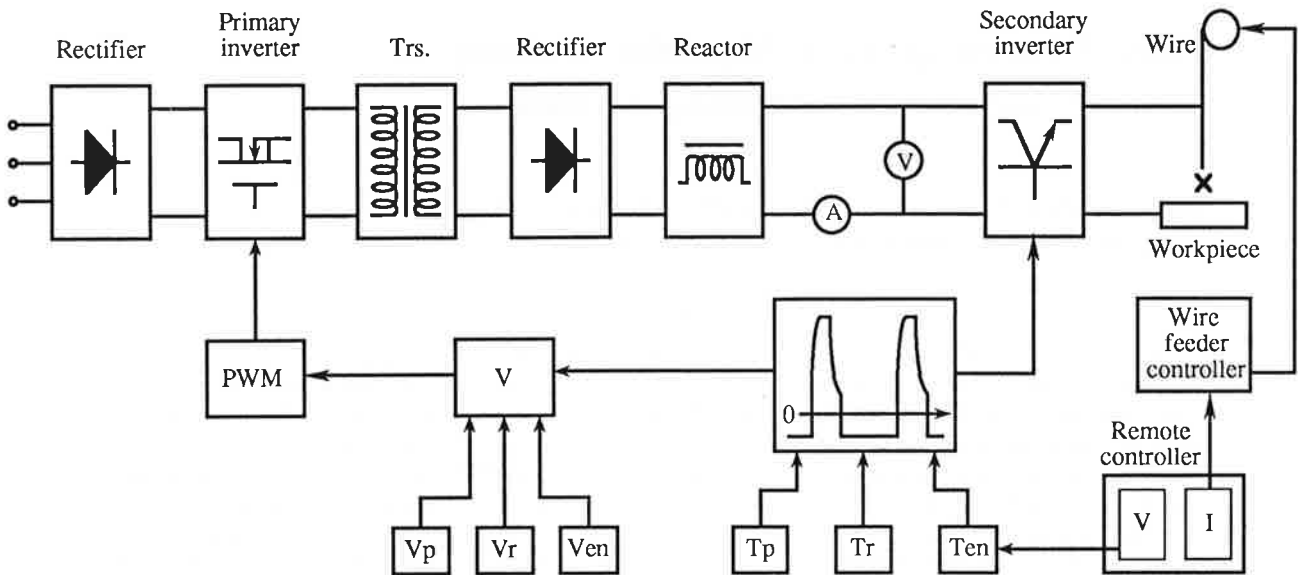

Fig.1 Schematic diagram of the AC-pulsed GMA inverter welder

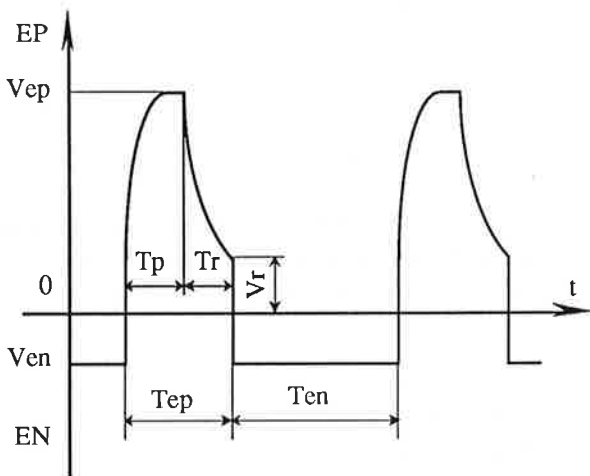

Fig.2 Waveform control for AC-pulsed GMA welder

to V_r , the secondary inverter switches voltage polarity from electrode positive(EP) to electrode negative(EN). The output voltage in EN duration (T_{en}) is controlled to V_{en} . After time T_{en} , which is given by the remote controller as welding voltage, the polarity is switched again to EP. AC pulse waveform control is realized by repeating the above-mentioned operation. If the polarity is not switched from EP to EN, the welding power source becomes a DCEP-pulsed welder and the base voltage V_b is of the absolute value of V_{en} . Figure 3 shows the current waveform of both DCEP-pulsed welding and AC-pulsed welding.

2.2 Sampling technique

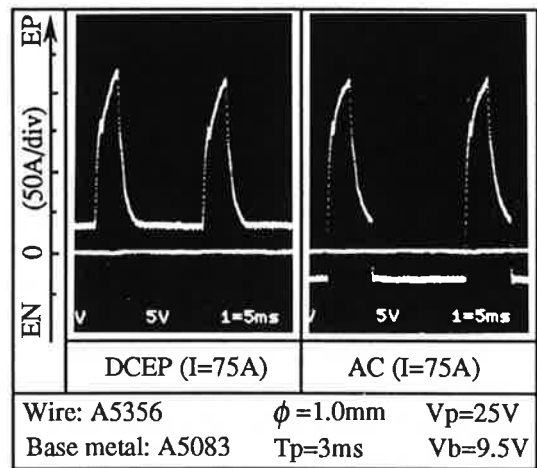

Fig.3 Current waveform of DCEP and AC pulse

Fume collection is carried out referring to the Japanese Industrial Standard (JIS) Z 3930, "Method of Measuring Total Amount of Weld Fumes Generated by Covered Electrode". The summary is as follows:

By means of automatic bead-on-plate welding inside a chamber as shown in Fig.4, practically all of the fumes generated are collected on the 20.3x25.4 glass fiber filter paper placed in the front of a high-volume air sampler that has a suction capacity of 1800 l/min. Welding speed is set at 500 mm/min. Contact tip to work distance is fixed to 15mm and flow rate of argon is 15 l/min. Arc voltage V_a for this test is set to the optimum value at which fume generation is lowest. Two pieces of test plate are welded for one sampling, and the welding time is $30\text{sec} \times 2 = 60\text{sec}$. Sampling begins at the same time as the

Table 1 Specification, alloy type and dimension of the welding materials tested

Filler metal wire			Base metal		
Specification	Alloy type	Diameter	Specification	Alloy type	Dimension(mm)
A1100	Pure Al	1.0mm	A5083	Al-Mg	300×50×3
A5356	Al-Mg	1.0mm	A7075	Al-Zn-Mg	300×50×3

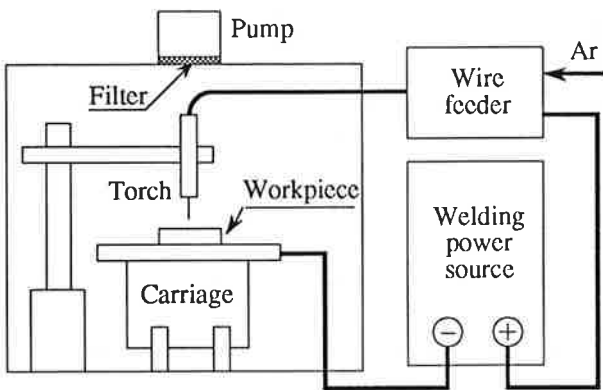

Fig.4 Schematic diagram of weld fumes collection set-up

arc starts and continues for 90 seconds for every piece of test plate welded. The filter paper is weighed just before and after each sampling to get the mass of fumes generated. Then the fumes are carefully swept off the filter paper with a soft brush and are accumulated again for X-ray diffraction analysis. Welding materials used in the experiment are shown in Table 1.

2.3 Droplet transfer observation

The droplet transfer process is observed using a high speed video camera (FASTCAMA-ultima) operating at 9000 frames per second. Pictures of interest are printed by a video printer. Photography is enhanced by a Xenon back light which reduces interference from arc brightness.

3. Results and Discussion

Effects of alloying elements both in filler metal wires and base metals are shown in Fig.5. Fume generation per unit mass of wire (Fw) for filler metal wire A5356 is about 3~4.5 times greater than that for A1100 when welding is carried out with a DCEP pulse process. On the other hand, there is no remarkable difference in Fw between A1100 and A5356 when welded with an AC pulse process. It is obvious that Mg contained in A5356 plays a very important role on fume formation in a

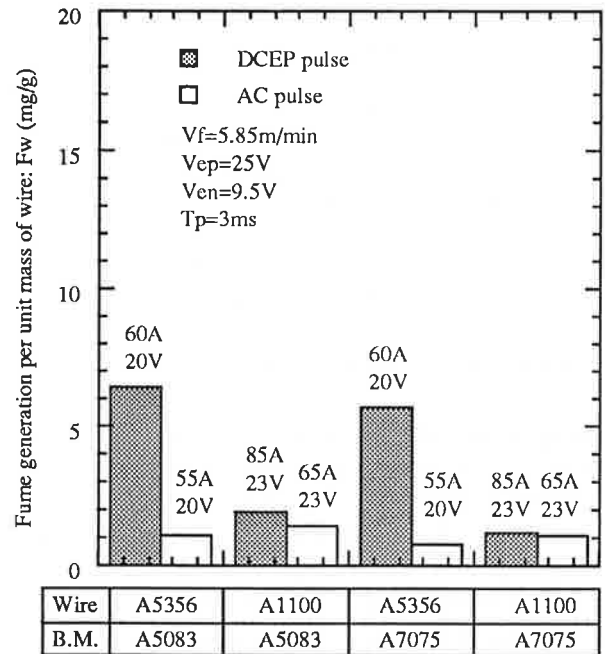

Fig.5 Effect of polarity and welding materials on fume generation

DCEP pulse process, and an AC pulse process is able to suppress its effect successfully. Although the concentration of high vapor pressure Zn in base metal A7075 is as much as 5.6%, no great changes of Fw are found compared to base metal A5083 welded with A5356, or A1100 filler metal wire under the same welding conditions. It seems that an alloying element in base metal contributes little to fume generation.

The effect of welding current on fume generation is shown in Fig.6. With an increase in welding current, Fw increases slowly for both the DCEP pulse process and AC pulse process. The DCEP pulse process generates much more fumes than the AC pulse process over the welding current range tested.

Arc voltage has a great effect on fume generation, as shown in Fig.7. There exists an optimum range of arc voltage (20~22V) in which Fw is lowest for both the DCEP pulse process and AC pulse process. Fw increases

Fume Generation in Al-Mg Alloy Welding

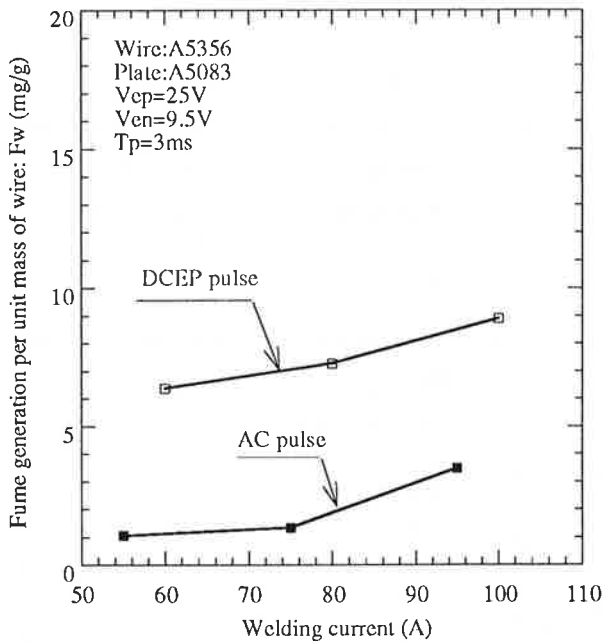

Fig.6 Effect of welding current on fume generation

sharply as arc voltage decreases below 20V, or increases above 22V for a DCEP pulse process. But the Fw of an AC pulse process does not change so sharply. Fume generation in an AC pulse process is less affected by arc voltage than that in a DCEP pulse process.

The composition of weld fumes collected from both a DCEP pulse process and AC pulse process at different arc voltages is analyzed by X-ray powder diffraction; some results are presented in Fig.8. Clearly the fume generated in welding an Al-Mg alloy with A5356 as the filler metal wire consists mainly of MgO, Al₂O₃ and metal Al. For an AC pulse process, the peak of MgO is very weak at low arc voltage (d) and considerably stronger at high arc voltage (f) in comparison with the levels of Al₂O₃. On the contrary, the level of metal Al is quite strong at low arc voltage but becomes so weak at high arc voltage that it almost can not be identified. Mg vapor tends to be oxidized completely because it is more active. Al vapor should be easily oxidized when the arc is long so that almost no metal Al exists in the fume. In fumes of a DCEP pulse process, similar patterns are observed at low and high arc voltages.

These results are consistent with the droplet transfer phenomena. It is found through a high speed video camera that fume is generated mainly in the following ways: (1) metal vaporization from a droplet surface, which may be dominated by Mg; (2) droplet explosion; (3) instability caused by a short-circuit. Causes (2) and (3) give out much more metal vapor which should be dominated by Al. When arc voltage is increased by

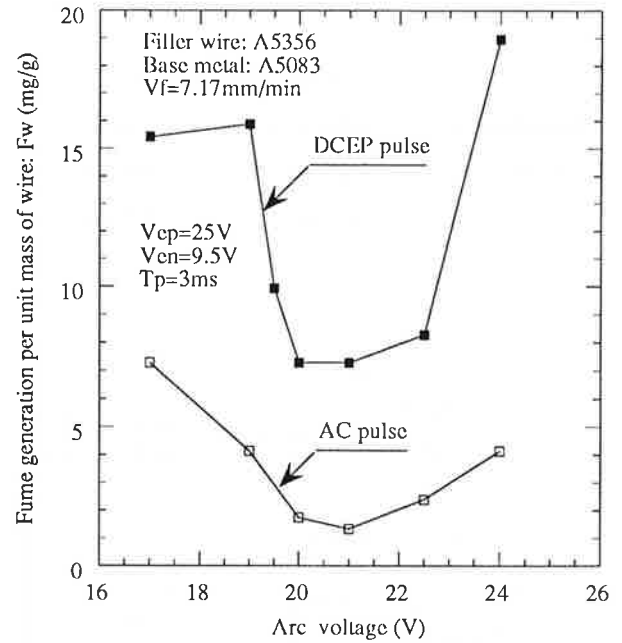

Fig.7 Effect of welding voltage on fume generation

shortening Ten or Tb, droplet detachment becomes difficult, and the droplet is overheated by more than one pulse. Droplet transfer becomes unstable as well. Consequently, fume generation increases via explanations (1) and (2). At low welding voltage, a short-circuit tends to occur, which increases fume generation. It should be pointed out that these phenomena occur more fiercely in a DCEP pulse process, and droplet explosion seldom takes place in an AC pulse process even at high arc voltage.

The difference between (b) and (e) in Fig.8 should be explained. Comparing the peak of Al₂O₃, it is found qualitatively that at the optimum arc voltage the concentration of MgO in the fume of a DCEP pulse process is higher than that of an AC pulse process. At optimum arc voltage, the droplet transfer in an AC pulse process with A5356 or A1100 as the filler wire is as stable as a DCEP pulse process with A1100, as shown in Fig.9. On the other hand, when welding is carried out with A5356 by a DCEP pulse process, although droplet transfer is much improved in comparison to a conventional welding process²⁾, the shape of droplets are still not regular, and droplet explosion sometimes occurs, i.e. the droplet transfer is still affected markedly by the presence of Mg in filler metal wire. This may suggest that the temperature of a droplet in a DCEP pulse process is lower than in a conventional DCEP process, but not low enough to control effectively the vaporization of Mg in it. Fume generation in a DCEP pulse process with A5356 as the filler wire seems mainly due to the vaporization of Mg from a droplet. Mg vaporization

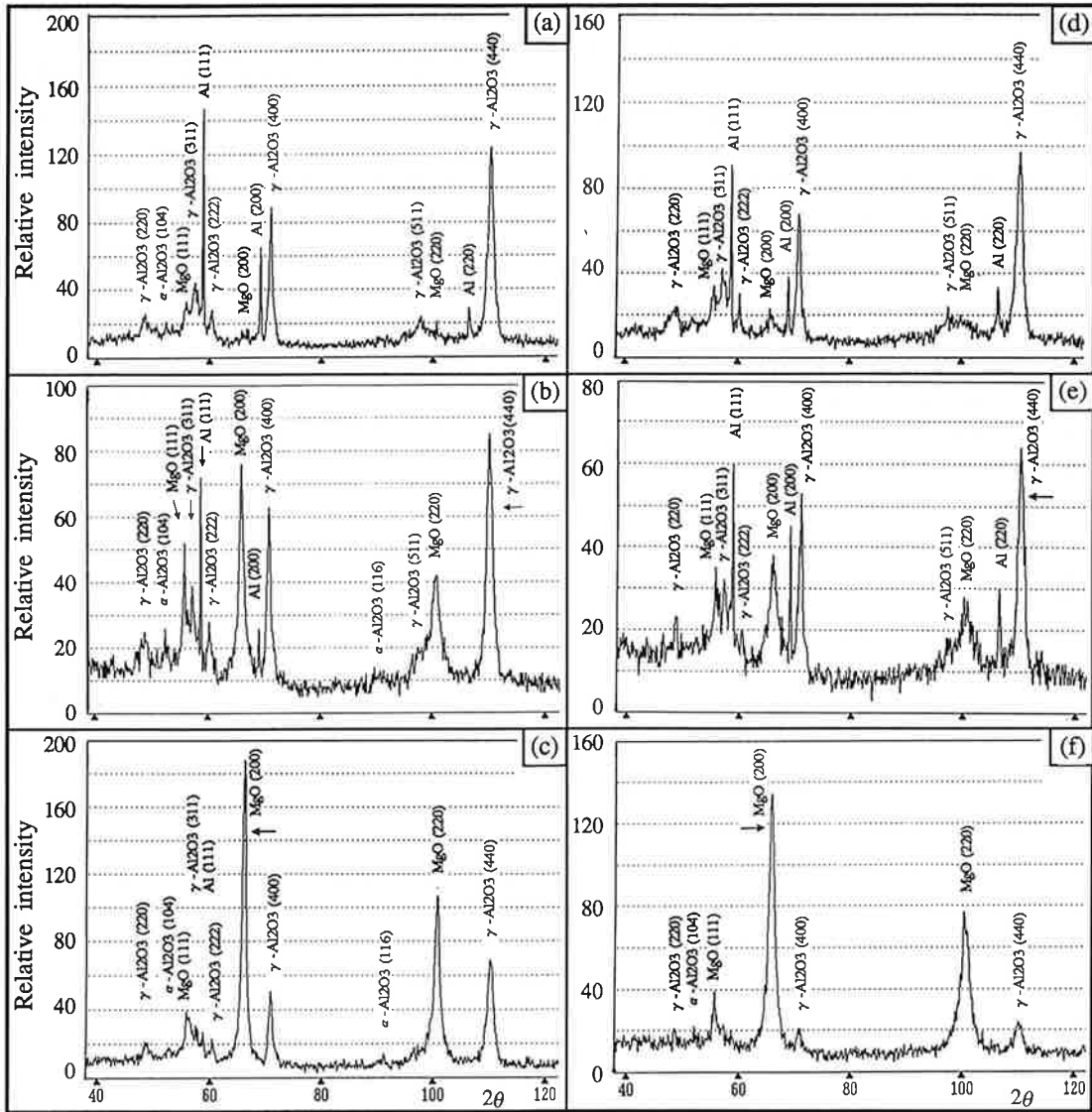

Fig.8 X-ray diffraction patterns of weld fumes
 Wire: A5356, Base metal: A5083
 DCEP pulse: (a) Va=18V; (b) Va=20V; (c) Va=23.5V
 AC pulse: (d) Va=18.5V; (e) Va=19.5V; (f) Va=24V

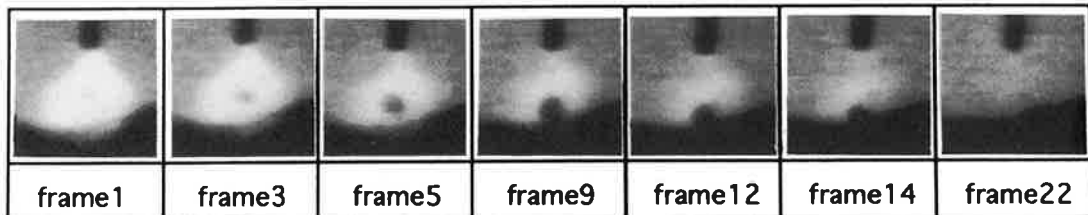

Fig.9 Droplet transfer of AC-pulsed GMA welding
 Welding voltage Va=20V, Welding current I=75A
 Wire: A5356, Base metal: A5083
 Recording rate: 9000 frames/sec

Fume Generation in Al-Mg Alloy Welding

causes instability in droplet transfer, which emits more Al and Mg vapor. On the other hand, because the droplet transfer in an AC pulse process with A5356 as the filler wire is extremely smooth, and because fume generation is minimal and the MgO concentration is lower compared to a DCEP pulse process, it becomes clear that Mg vaporization is successfully suppressed, and the temperature of droplet should be lower or well distributed.

4. Conclusions

- (1) In pulsed GMA welding of Al alloy with A5356 as filler metal wire, weld fume consists mainly of MgO, Al₂O₃ and metal Al.
- (2) In DCEP-pulsed GMA welding of Al alloy, the fume generation rate for filler metal wire A5356 is much higher than A1100 due to the presence of Mg. The vaporization of Mg from the droplet, droplet transfer

instability induced by Mg vaporization, and Mg and Al vaporization enhanced by this instability are considered to be the main reasons.

- (3) An AC-pulsed GMA inverter welder is able to suppress effectively the vaporization of Mg in droplets, achieve smooth droplet transfer, and markedly reduce the fume generation rate to 1/6~1/2 of that in DCEP pulse welding in the low welding current range tested. This effect exists over a large range of arc voltage.

References

- 1) Bob Irving, "Inverter Power Sources Check Fume Emissions in GMAW", *Welding Journal*, Feb. 1992, P53.
- 2) R.A. Woods, "Metal Transfer in Aluminum Alloys", *Welding Journal*, Feb. 1980, P59-s.