

Combined Effect of Current Pulsation and Zr Addition on Improvement of Solidification Cracking of Al-Zn-Mg Alloy Weld Metal[†]

— Effect of Additional Element on Weld Solidification Crack Susceptibility of Al-Zn-Mg Alloy (Report IV) —

Fukuhisa MATSUDA*, Kazuhiro NAKATA**, Kenji TSUKAMOTO*** and Shigetoshi JOHGAN***

Abstract

It was made clear that current pulsation in GMAW had a beneficial effect to improve the solidification crack susceptibility of Al-Zn-Mg alloy weld metal by using Zr-contained Al - 5 to 6%Mg tentative filler wires. This beneficial effect was due mainly to grain refinement in weld metal. However, there were an optimum value in pulse frequency of about 30 Hz and minimum content of Zr to be contained in weld metal, that is, about 0.15% within the limited condition in this study. Unless these two requirements were not satisfied, this beneficial effect of current pulsation did not appear.

KEY WORDS: (Aluminum Alloy) (Al-Zn-Mg Alloy) (Solid Filler Wire) (Pulsed GMA Welding) (Grain Refinement) (Hot Cracking) (Solidification Cracking) (Zirconium)

1. Introduction

Zirconium (Zr) is one of the most effective alloying elements to reduce the solidification crack susceptibility of the weld metal of Al-Zn-Mg alloy¹⁻⁶). This beneficial effect of Zr is due mainly to the grain refinement of the weld metal structure^{1,2,5}).

It was made clear in the previous report⁷) that more than 0.3%Zr was required to be contained in Al-Zn-Mg alloy weld metal in order to get a fully refined grain structure with GTA welding. However, it is very difficult to add such a large amount of Zr to aluminum alloy in commercial welding and casting processes.

On the way, when an adequate agitation of molten metal in weld pool was introduced, only about 0.2%Zr was enough to get a fine-equiaxed structure and the same time, crack susceptibility of weld metal was enough lowered as the same manner observed in the case of more than 0.3% Zr addition⁸).

Among methods of weld pool agitation to emphasize the grain refinement of Zr, it is considered that both electromagnetic stirring and current pulsation are the most

effective methods. In the case of the application of these two methods to commercial GMA welding process, however, current pulsation, namely pulsed GMA welding is considered to be more advantageous than electromagnetic stirring because of the next reasons; the first is that the latter needs magnetic coil to be equipped with welding torch and/or to be set under the backside of work piece, and this disturbs the applicability of welding process. As the next reason, sputtering was much increased by the influence of an external magnetic field to metal transfer in GMA welding process⁹).

Nextly as to the Zr content of weld metal, when A7N01 base metal, typical Al-Zn-Mg alloy, is welded with Al-5%Mg alloy filler wire which is commonly used for GMA welding of this alloy, the Zr content in weld metal is less than about 0.1%, and according to the previous report⁸) this will be not enough to get grain refinement in weld metal, even if weld pool agitation is introduced.

Therefore, in order to increase the Zr content in weld metal as much as possible, Zr-contained filler wire was experimentally made and utilized for GMA welding of A7N01 alloy, and at the same time current pulsation was

[†] Received on 31st October, 1985

* Professor

** Research Associate

*** Showa Aluminum Corporation

Transactions of JWRI is published by Welding Research Institute of Osaka University, Ibaraki, Osaka 567, Japan

also used to emphasize the grain refinement effect of Zr by agitating molten metal in weld pool.

For comparison, some other tentative filler wires as high Mg-contained filler wire (Al-6 to 7%Mg alloy) with or without Zr or Ti + B (titanium with boron) were also utilized.

Moreover, as it is expected that grain refinement is much influenced with pulse conditions, mainly pulse frequency¹⁰⁾, the effect of pulse frequency on the degree of grain refinement was examined and at the same time, crack susceptibility of weld metal was evaluated with GMAW Fish-bone type test specimen.

2. Materials Used and Experimental Procedures

2.1 Materials used

An typical Al-Zn-Mg alloy, A7N01-T5 of 6 mm thick plate as base metal, and a commercial A5356 (Al-5%Mg) and tentative Al-5%Mg with 0.23%Zr or small amount of Ti + B and Al-6 to 7%Mg with or without Zr or Ti + B alloys as filler wire of 1.6 mm diameter were used for GMA welding test. Chemical compositions of these alloys are shown in Table 1.

2.2 Experimental procedures

2.2.1 Pulsed GMA welding

Pulsed GMA welding was performed by a transistor-generated welder (Max. 800 A) under the constant voltage mode. A typical sketch of current and voltage waveforms is shown in Fig. 1 showing terminology for pulsed welding used. Welding conditions used are shown in Table 2, which made a full penetration and smooth back surface of weld bead of about 15 and 7 mm widths of top and back weld bead surfaces. Among parameters of welding condition, only pulse frequency was varied in this experiment from zero (direct current, DC mode) up to 60 Hz. The crosssectional configuration of weld bead was not so changed with pulse frequency.

2.2.2 Weld solidification cracking test

Solidification crack susceptibility of weld bead was evaluated by means of GMAW Fish-bone type test specimen as shown in Fig. 2. GMA welding was started on a 6 mm thick tab plate of A7N01 and then performed with a constant welding speed from deep slit side to opposite

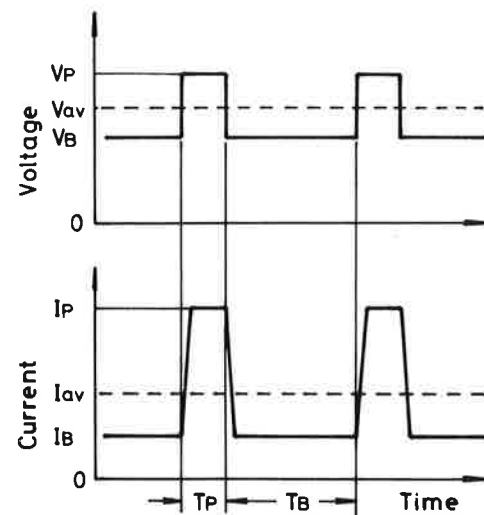

Ip : Peak current Vp : Peak voltage
Ib : Base current Vb : Base voltage
Iav : Average current Vav : Average voltage
Tp : Peak current duration
Tb : Base current duration

Fig. 1 Schematic pulse current and arc voltage waves.

Table 2 Welding parameters used.

Welding current Iav		Arc voltage Vav	Welding speed	Ip	Ib
195-205 A		28-29 V	6.67 mm/sec	390 A	150 A
Ip/Ib	Tp/Tb	Pulse frequency	Wire feed speed	Electrode extension	
2.6	1/3	DC-60 Hz	120 mm/sec	15 mm	

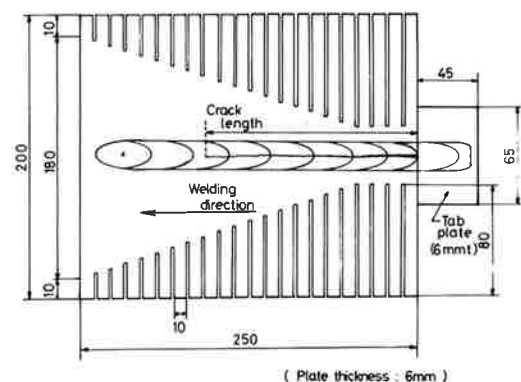

Fig. 2 GMAW Fish-bone cracking test specimen.

Table 1 Chemical compositions of materials used.

Materials		Chemical compositions (wt%)										Remarks
		Si	Fe	Cu	Mn	Mg	Cr	Zn	Ti	Zr	B	
Base metal	A7N01	0.07	0.16	0.09	0.48	1.13	0.20	4.50	0.03	0.13	-	6 mm
Filler wire	A5356	0.05	0.14	0.01	0.09	4.82	0.10	Tr	0.09	-	-	1.6 mm diam.
	5356Ti+B	0.06	0.14	Tr	0.11	4.88	0.09	Tr	0.11	-	0.002	
	5356Zr	0.05	0.11	Tr	0.12	4.96	0.09	0.01	0.01	0.23	-	
	7Mg	0.08	0.17	Tr	0.12	7.22	0.11	0.01	0.07	-	-	
	6MgTi+B	0.03	0.16	Tr	0.12	6.34	Tr	0.09	0.07	-	0.004	
	6MgZr	0.05	0.17	Tr	0.12	6.60	Tr	0.09	0.01	0.25	-	

side under the welding condition as shown in Table 2. The crack susceptibility of weld metal was evaluated by a percent ratio of crack length measured on weld bead surface to the length of test specimen of 250 mm.

2.2.3 Metallurgical investigations

Macrostructure of the weld bead was chemically etched with dilute Tucker's reagent, and microstructure of weld metal was electrochemically etched with Barker's reagent and observed under a polarized lighting. Grain size of weld metal structure was measured on the microphotographs by means of line-intersection method.

3. Results and Discussions

3.1 Grain structural change in weld metal caused by current pulsation

At first, effect of pulse frequency on grain refinement was investigated by using a commercial A5356 and a tentative 5356Zr wires under the limited condition ($I_p/I_B = 2.6$, $T_p/T_B = 1/3$) of pulsed GMA welding as shown in Table 2.

Figure 3 shows grain structures of weld metal on the longitudinal crosssection along weld centerline.

In DC mode, the weld structure made with 5356 consisted of coarse columnar grains and that with 5356Zr also consisted of columnar (or stray crystal) grains, but the latter was finer than the former due to the increased Zr content.

With current pulsation of 15 and 20 Hz, no significant change in grain structure was occurred for each filler wires. Increasing the frequency to 30 Hz, remarkable grain

refinement was observed in the case of 5356 Zr, of which grain structure consisted entirely of very fine equiaxed grains as observed in the case of electromagnetically-stirred weld bead⁸). Increasing the frequency to 40 Hz, however, the degree of grain refinement became less and banded structure of comparably large stray crystals became to be appeared. At 60 Hz, there was no grain refinement observed in weld metal and grain structure was almost the same as that of DC mode. On the contrary, in the case of 5356, grain refinement was also observed at 30 Hz, but not so remarkable.

These differences between two wires depended on the Zr content in weld metal as shown in Table 3 which showed the chemical compositions of Mg, Zn and Zr in weld metal. Mg and Zn contents were almost not varied against the variation of pulse frequency and also the kind of filler wire, that is, 2.1 – 2.3% and 2.9 – 3.1%, respectively. However, by using 5356Zr wire, Zr content was

Table 3 Mg, Zn and Zr contents in weld metals made with A5356 and 5356Zr wires.

Filler wire	Pulse frequency	Chemical composition (wt%)		
		Mg	Zn	Zr
5356	DC	2.27	2.89	0.09
	15Hz	2.15	2.98	0.09
	20Hz	2.14	3.00	0.09
	30Hz	2.19	3.05	0.09
	40Hz	2.10	3.06	0.09
	60Hz	2.15	3.07	0.09
5356Zr	DC	2.25	2.96	0.15
	15Hz	2.15	3.05	0.15
	20Hz	2.09	3.01	0.15
	30Hz	2.16	3.01	0.15
	40Hz	2.12	3.02	0.15
	60Hz	2.16	2.89	0.16

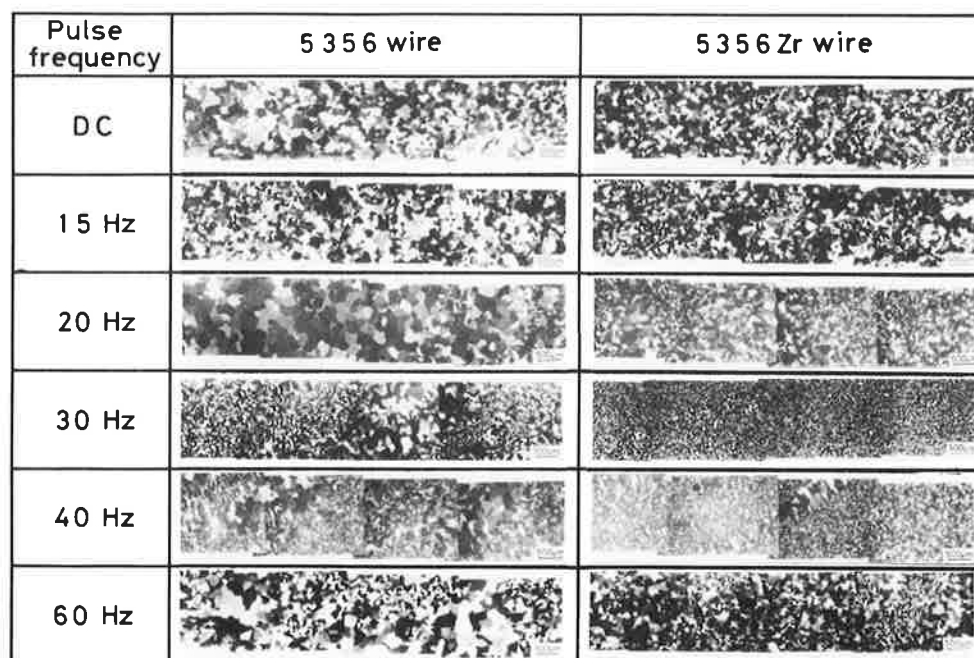

Fig. 3 Grain structures on crosssections of weld bead for various pulse frequencies with A5356 and 5356Zr wires

increased to about 0.15% in weld metal in comparison with 0.09% with commercial A5356 wire.

Consequently, it became clear that current pulsation was very effective to grain refinement of GMA weld metal of Zr-contained Al-Zn-Mg alloy, but there existed the limitations in optimum pulse frequency and minimum content of Zr to be contained in weld metal. In this study, those are 30 Hz in pulse frequency and 0.15% of Zr content in weld metal. However, it seems that these two limitations are not independent but have a mutual correlation for each other and the increase in Zr content in weld metal will widen the optimum frequency range for grain refinement.

3.2 Effect of pulse frequency on crack susceptibility of weld metal

Grain structure of weld metal was much changed with pulse frequency. In this section the relation between crack susceptibility and grain structure was examined for the variation of pulse frequency.

Figure 4 shows the effect of pulse frequency on crack susceptibility of weld metal made with A5356 and 5356Zr wires.

In DC mode (without pulsation), weld bead showed high susceptibility of cracking for both filler wires because of coarse columnar and/or stray crystal grain structures, and there was no significant difference between them.

However, remarkable decrease in crack susceptibility was observed in weld bead made with 5356Zr by introducing the current pulsation with 30 and 40 Hz in pulse frequencies. Especially with 30 Hz, it was much decreased. On the contrary, in the case of A5356 wire, the decrease in crack susceptibility was also observed at 30 Hz, but not

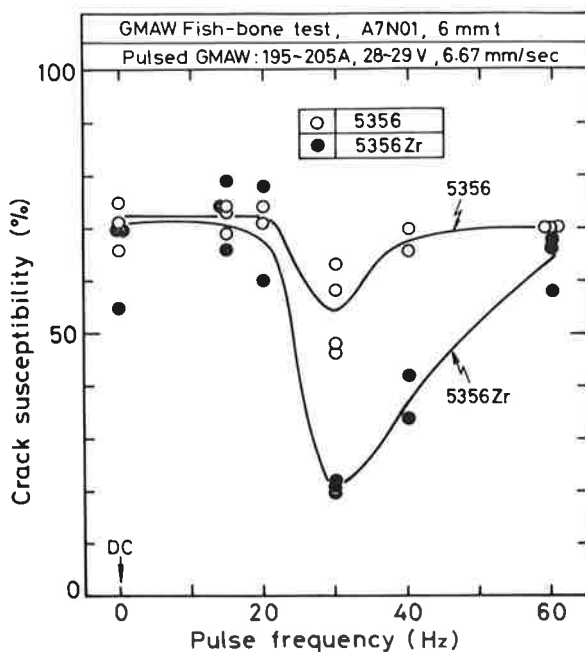

Fig. 4 Effect of pulse frequency on crack susceptibility of weld bead evaluated by GMAW Fish-bone test.

so remarkable. These optimum frequencies coincided with those for grain refinement for each filler wire. Therefore, fine-equiaxed grain structure such as that obtained with 5356Zr in 30 Hz is the most effective to improve the resistant to cracking.

On the contrary, with lower and higher frequencies than these optimum frequencies, however, no reduction in crack susceptibility was observed for each filler wire, and in these cases, columnar and/or stray crystal structure was dominant in weld metal.

Consequently, current pulsation in GMAW is very effective to reduce the crack susceptibility of Al-Zn-Mg alloy by using a Zr-contained filler wire, but its beneficial effect is only valid when weld-metal grain structure consists of fine-equiaxed one.

3.3 Difference in beneficial effect of current pulsation due to type of filler wire

Effect of current pulsation on crack susceptibility was examined for the various kinds of tentative filler wire as shown in Table 1 under the optimum pulse frequency of 30 Hz.

Figure 5 shows crack susceptibility of weld bead made with and without current pulsation for each filler wire.

In the case of DC mode, each weld bead showed high crack susceptibility and there was no significant difference in these values. On the contrary, by introducing current pulsation of 30 Hz, the decrease in crack susceptibility was observed for all filler wires. However, remarkable decrease in crack susceptibility was observed only in the case of Zr-contained filler wires as 5356Zr and 6MgZr. The decrease in crack susceptibility for other wires were

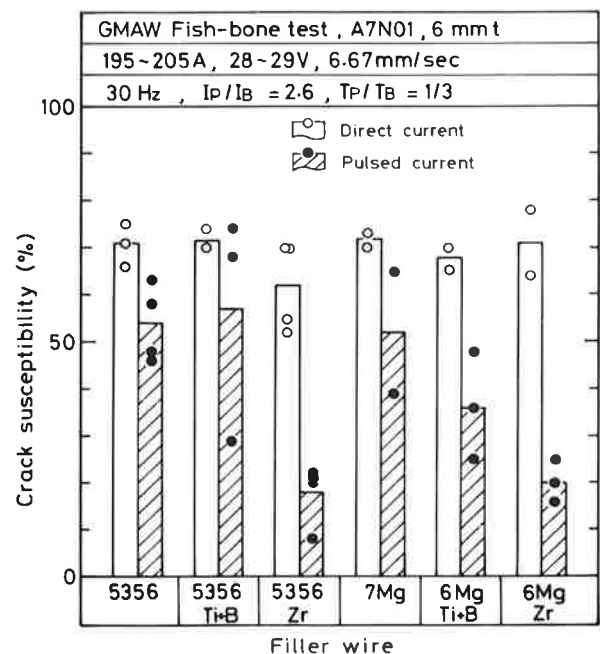

Fig. 5 Effect of current pulsation on crack susceptibility of weld bead for various kinds of filler wires at pulse frequency of 30 Hz for comparison with DC mode.

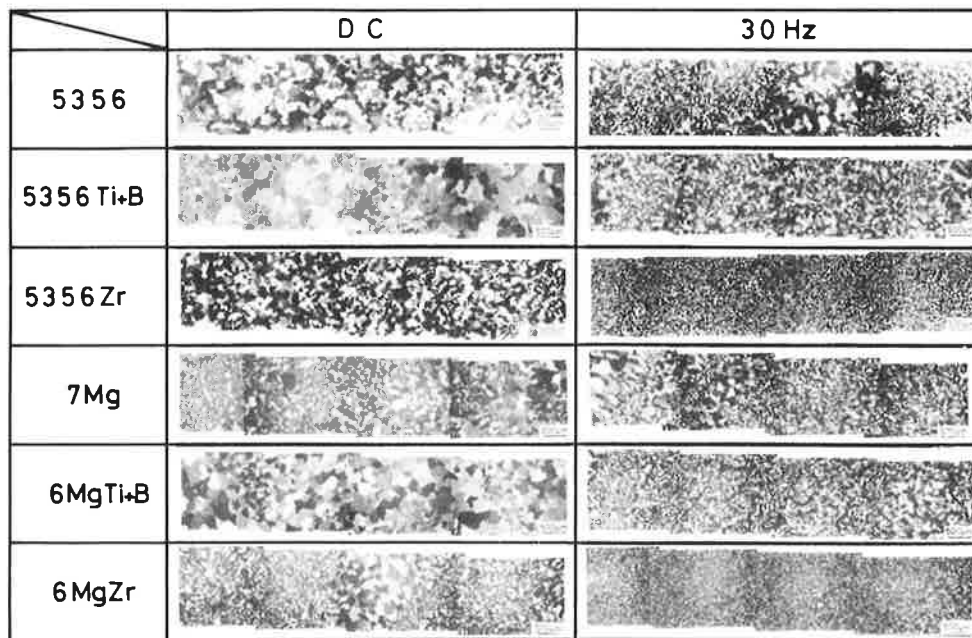

Fig. 6 Grain structural changes caused by current pulsation of 30 Hz for various filler wires.

not so remarkable, though 6MgTi+B wire showed fairly decrease, but less than Zr-contained wires.

Figure 6 shows grain structures on the longitudinal crosssection of weld bead for comparing those with and without pulsation for each filler wire.

In DC mode, the grain structures of all the weld beads consisted of columnar and/or stray crystals, though with Zr-contained wires fine-grained zone was sometimes observed.

By introducing current pulsation of 30Hz, Zr-contained two filler wires showed completely grain-refined equiaxed structure. With other filler wires grain refinement was also observed in some degree, but not so remarkable in comparison with Zr-contained wires. Among them, 6MgTi+B showed a fairly grain refinement, though some banded structures of stray crystals were still observed.

According to these results, crack susceptibility of weld bead was closely related to grain structure and it was confirmed that fine-equiaxed grain structure was beneficial to reduce the solidification crack susceptibility.

Moreover, in Fig. 5 considerable scattering in crack susceptibility was observed with 5356Ti+B and 7Mg wires under pulsation. In these cases, weld beads with lower crack susceptibility showed smaller grain structure. However, grain refining effect of these two wires was unreliable.

Therefore, it is considered that in order to get fine-equiaxed structure, Zr-contained filler wire of Al-5 to 6%Mg alloy is the most adequate and reliable one for pulsed GMA welding of Al-Zn-Mg type base alloy.

In addition to this, according to the ring-casting test results, among tentative filler wires, high Mg-contained

wire was considered to be a desirable one to prevent weld solidification cracking of Al-Zn-Mg alloy¹¹). However, there observed no significant decrease in crack susceptibility in comparison with ordinal Al-5%Mg (A5356) filler wire in the case of weld bead cracking evaluated by GMAW Fish-bone type test. This is considered to be due mainly to the difference in grain structure between casted and welded metal. In ring-casting, increasing the Mg content made the decrease in grain size¹²). On the contrary, grain structure of weld bead showed almost no grain refinement by using high Mg (Al-7%Mg) wire as shown in Fig. 6.

3.4 Grain-size effect on crack susceptibility

Figure 7 shows the relation between mean grain size of weld metal and crack susceptibility for typical weld beads tested in sections 3.2 and 3.3.

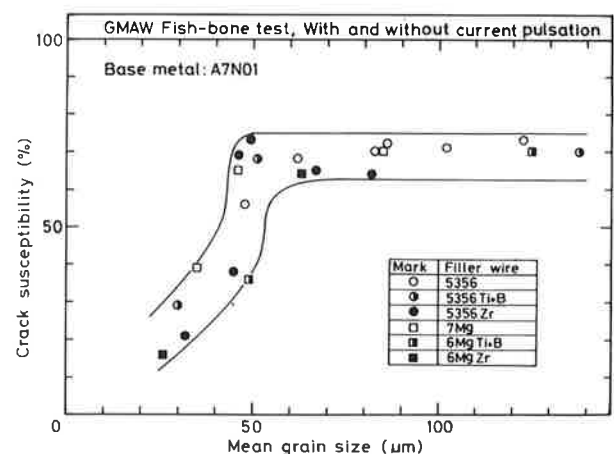

Fig. 7 Relation between grain size of weld structure and crack susceptibility for various kinds of filler wires.

When grain size decreased less than about 50 μm , crack susceptibility was abruptly and progressively decreased with the decrease in grain size. On the contrary, with larger grain size than about 50 μm , crack susceptibility showed high value, independent to grain size. This relationship was almost independent on the type of filler wire used.

These results clearly indicate that crack susceptibility of weld bead of Al-Zn-Mg alloy depended mainly on grain size and also beneficial effect of current pulsation to reduce crack susceptibility was due mainly to grain refinement.

3.5 Other effect of current pulsation

There was no significant change in the shape of weld bead for the difference of filler wire and the pulse frequency. However, in the case of 15 and 20 Hz, the shape of weld pool showed small changes and it became to look like tear-drop type and surface of weld bead became to be slightly humpy along the weld bead center. Almost the same phenomena was observed in electromagnetically-stirred GTA weld bead in case of strong stirring condition.

In addition, sputtering was much increased in this frequency range, though without and with pulsation of more than 30 Hz welding was smooth and sputtering was less.

4. Conclusions

Effect of current pulsation on grain refinement and solidification crack susceptibility of GMA weld metal of Al-Zn-Mg alloy have been investigated with Al-5 to 7%Mg alloy with and without Zr or Ti + B as filler wires.

Main conclusions obtained are as follows;

- 1) Current pulsation was very effective to get fine-equiaxed grain structure of GMA weld bead of Al-Zn-Mg (A7N01) alloy by using tentative 0.23 – 0.25% Zr-contained Al-5 to 6%Mg alloy as filler wires.
- 2) There existed two limitations for grain refinement by

current pulsation; one was optimum frequency of current pulsation of about 30 Hz and the other was minimum content of Zr to be contained in weld metal, that is, about 0.15% within the limited condition of this study.

- 3) When the above two limitations were satisfied by introducing current pulsation and Zr-contained filler wire, the solidification crack susceptibility of GMA weld bead of A7N01 alloy was significantly reduced.
- 4) Solidification crack susceptibility of GMA weld bead of A7N01 was generally decreased with the decrease in grain size of weld grain structure.

Acknowledgements

The authors wish to express their thanks to Mr. U Nakao and U. Suminaga, students of Faculty of Engineering, Kinki University for their helpful assistants.

References

- 1) G.L. Petrov, A.G. Makarov: *Automatic Weld.*, **14** (1961) 9, 18–24.
- 2) J.H. Dudus, F.A. Collins: *Weld. J.*, **45** (1966) 6, 241s–249s.
- 3) F.E. Gibbs: *Weld. J.*, **45** (1966) 10, 445s–453s.
- 4) S. Sugiyama, T. Fukui: *J. of Japan Welding Society*, **36** (1967) 11, 1194–1202.
- 5) J.G. Young: *Weld. J.*, **47** (1968) 10, 451s–461s.
- 6) T. Tanaka, S. Yoshida: *J. of Japan Institute of Light Metals*, **19** (1969) 11, 470–480.
- 7) F. Matsuda, K. Nakata, K. Tsukamoto, K. Arai: *Trans. JWRI*, **12** (1983) 2, 253–262.
- 8) F. Matsuda, K. Nakata, T. Tsukamoto, T. Uchiyama: *Trans. JWRI*, **13** (1984) 1, 57–66.
- 9) K. Tsukamoto: Private communication.
- 10) F. Matsuda, M. Ushio, K. Nakata, Y. Niyana: *Trans. JWRI*, **7** (1978) 2, 287–289.
- 11) K.P. Mudrak: *Schw. und Schn.*, **12** (1960) 2, 45–55.
- 12) K. Nakata, Y. Miyana, F. Matsuda, K. Tsukamoto, K. Arai: *Trans. JWRI*, **9** (1980) 2, 205–216.