

Effect of Additional Element on Weld Solidification Crack Susceptibility of Al-Zn-Mg Alloy (Report II)[†]

—Results of Weld Crater and Bead Cracking Tests—

Fukuhisa MATSUDA*, Kazuhiro NAKATA**, Kenji TSUKAMOTO*** and Kohzoh ARAI***

Abstract

Crack susceptibility of weld crater and weld bead of synthesized-weld-metal Al-2%Zn-3%Mg-0.1%Zr alloy with and without Zr, Ti and/or Ti+B (Ti with B) have been evaluated by means of GTA spot weld crater and Houldcroft-type weld bead cracking tests, respectively.

Crack susceptibility of weld crater of synthesized-weld-metal alloy was reduced enough with more addition than 0.36%Zr, 0.14%Ti or 0.07%Ti+B in this experiment. Macrostructural investigation revealed that crack susceptibility of weld crater depended on grain refining effect of these additional elements and it was decreased as decrease in grain size almost independently of the kind of additional element.

Among these additional elements, however, only Zr showed the marked beneficial effect to reduce the crack susceptibility of weld bead with more addition than 0.24%Zr. This beneficial effect of Zr was closely related with grain refinement of weld bead structure. There were no beneficial effect of Ti or Ti+B addition up to 0.83% or 0.49% respectively to reduce the crack susceptibility of weld bead in spite of fine equiaxed structure of weld bead in this experiment.

Consequently, it was proved that Zr was the most beneficial additional element to reduce the crack susceptibility of both weld crater and weld bead, and Ti or Ti+B were almost no effect to reduce the weld bead cracking, though they showed remarkable effects to reduce the weld crater cracking.

KEY WORDS: (Solidification Cracking) (Aluminum Alloy) (Al-Zn-Mg Alloy) (GTA Welding) (GMA Welding) (Grain Refinement) (Structure)

1. Introduction

Research program has been performing to make a favorable filler wire to prevent the weld cracking of 7N01 Al-4.5%Zn-1.2%Mg alloy.

In the previous report¹⁾, the selection of the favorable additional element to reduce the susceptibility of solidification crack of Al-Zn-Mg alloy was performed by means of ring-casting cracking test. This test results showed that zirconium (Zr), titanium (Ti) and Ti+B (titanium with boron) were proved to be the most effective additional element to reduce the solidification cracking.

In this report, on the basis of these results, effects of Zr, Ti and/or Ti+B additions on the susceptibilities of solidification cracking of actual weld crater and weld bead has been investigated by means of GTA spot weld crater and Houldcroft-type weld bead cracking tests respectively, for synthesized-weld-metal Al-2%Zn-3%Mg-

0.1%Zr alloy.

Moreover grain-size effect on crack susceptibility of weld crater and weld bead has been discussed.

From these results, beneficial additional element and its adequate amount of the addition to filler wire in order to prevent the weld cracking of 7N01 alloy was recommended.

2. Materials Used and Experimental Procedures

2.1 Materials used

The synthesized-weld-metal alloy, shortly the SWM alloy, of which nominal chemical composition is 2%Zn, 3%Mg, 0.3%Mn, 0.2%Cr and 0.1%Zr with small amount of Fe and Si balanced aluminum was used. This nominal composition was decided due to the actual composition

[†] Received on October 31, 1983.

* Professor

** Research Associate

*** Research Engineer, Showa Aluminum Corporation

Transactions of JWRI is published by Welding Research Institute of Osaka University, Ibaraki, Osaka 567, Japan

of weld metal of 7N01 Al-4.5%Zn-1.2%Mg-0.16%Zr base metal with 5356 Al-5%Mg filler wire with MIG arc welding. Additional elements of Zr, Ti and Ti+B were added by Al-5%Zr, Al-5%Ti and Al-5%Ti-1%B mother alloys respectively onto this SWM base alloy to the extent of 0.44%, 0.83% and 0.49% respectively. The content of "Ti+B" shows the amount of Ti only, and boron content is about one to five of Ti content in this experiment. These SWM alloys were hot- and cold-rolled to 2 mm in sheet thickness and fully annealed.

2.2 Weld solidification cracking test

Cracking susceptibilities of weld crater and weld bead were evaluated by means of GTA spot weld crater and Houldcroft-type weld bead cracking tests respectively, of which test specimens were illustrated in Fig. 1(a) and (b), respectively.

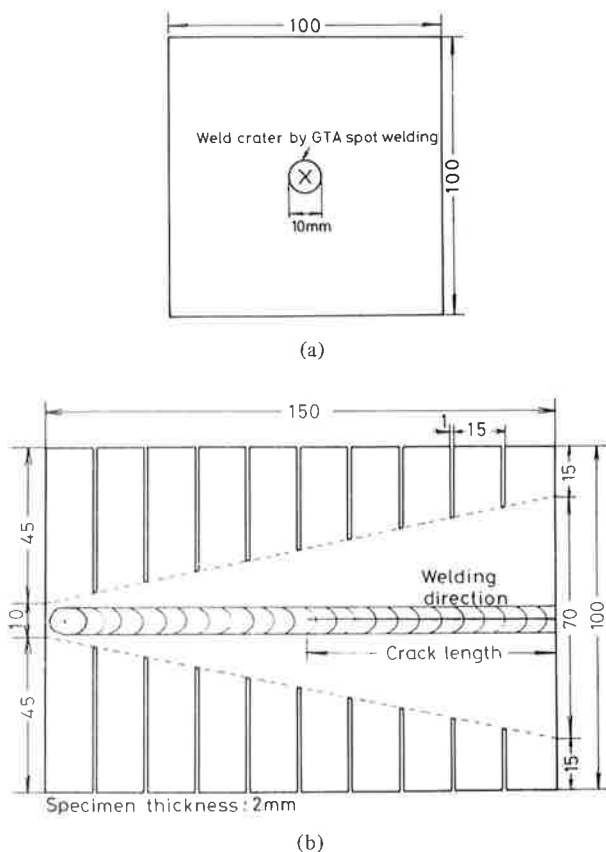

Fig. 1 Configurations of test specimens of (a) GTA weld crater and (b) Houldcroft-type weld bead cracking tests.

In Fig. 1(a), a weld crater was made on a square sheet of 100 mm in width and 2 mm in thickness by GTA spot welding with the welding condition of 100A of arc current (AC), 18V of arc voltage and 6 sec of arc holding time under the argon shielding gas (flow rate: 101/min.).

In this welding condition diameters of weld crater on top and back surfaces were almost equal, that is, about 10 mm. The total length of cracks observed on top surface of the weld crater was measured by micrometer and the cracking index was represented by the ratio in percentage of the total length of cracks to the diameter of the weld crater. The number of the repetition of cracking test for each alloy was 3 and mean value of each cracking index obtained was adopted as the criteria for the evaluation of the susceptibility of weld crater cracking. In Fig. 1(b), GTA bead-on-plate welding without filler wire was performed along the center of test specimen by using the automatic carriage of which travel speed was preset to 300 mm/min with 100 A of welding current (AC) and 18V of arc voltage under argon shielding gas (101/min of flow rate). This welding condition was selected in order to make a weld bead with an almost uniform width of 8 to 9 mm on both sheet surfaces. Moreover to make a full-penetrated weld bead, traveling was started after specimen edge was melted enough. In this type of test specimen, the travel speed should be lower than 300 mm/min²).

The specimen was restrained by a jig for fixture with roller bearings not to make a distortion vertical to sheet surface without restraint of a deformation of test specimen parallel to sheet surface. In this cracking test, a centerline cracking in weld bead usually occurred along welding line as shown schematically in figure. The percent ratio of a full length of crack to specimen length of 150 mm was adopted by the criteria to evaluate the crack susceptibility of weld bead. The repetition of cracking test was 2 to 10 for each test alloy.

3. Experimental Results

3.1 Susceptibility of weld crater cracking

(1) Addition of individual element of Zr, Ti or Ti+B

Effect of Zr addition on Zr free SWM alloy on weld crater cracking was shown in Fig. 2(a), and those of Ti or Ti+B additions on the SWM alloy was also shown in Fig. 2(b).

In case of Zr addition, small amount of Zr addition abruptly increased the crack susceptibility of Zr free SWM alloy and Zr content of about 0.1% showed the highest susceptibility. This Zr content almost equal to that of nominal composition of SWM alloy. However, more addition of Zr remarkably decreased the crack susceptibility, and favorable amount of Zr to reduce the crack susceptibility enough low was required to be more than 0.36% in this experiment.

The much more favorable effect than that of Zr was

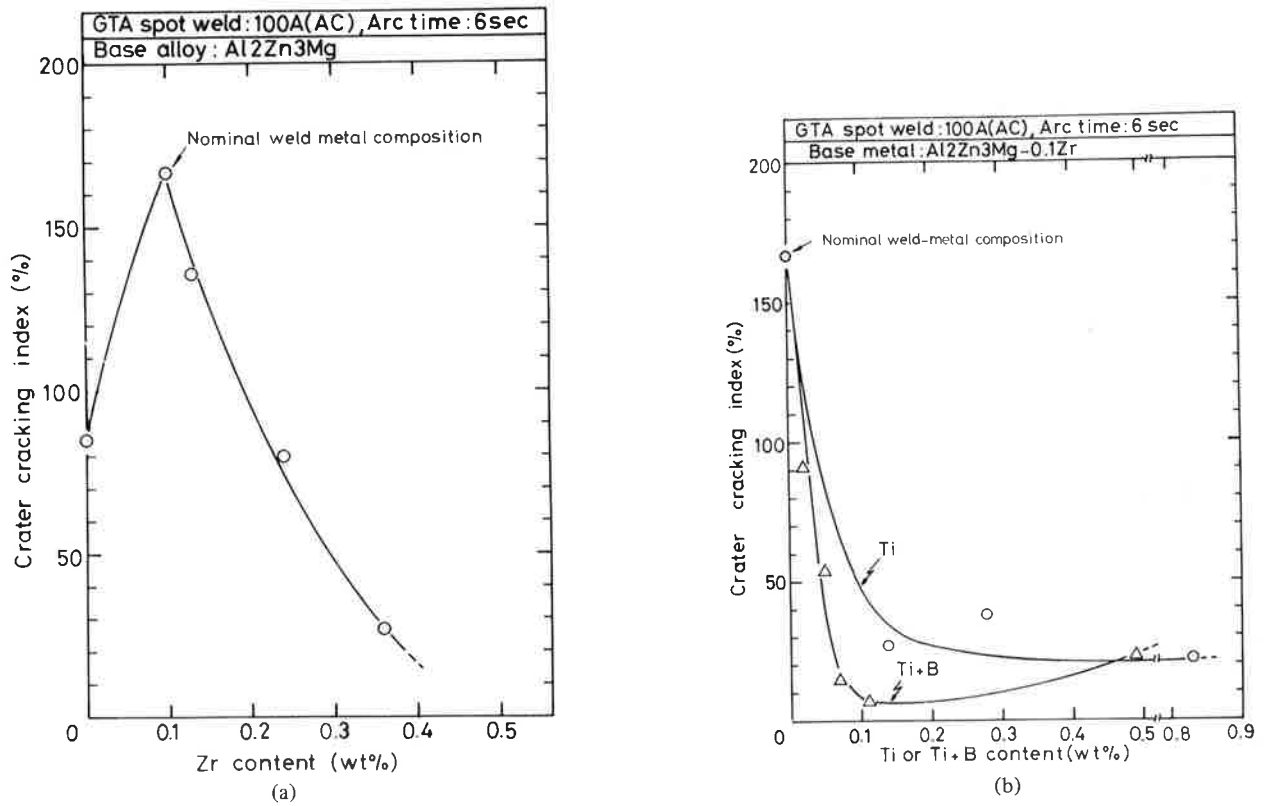

Fig. 2 Effects of Zr, Ti or Ti+B additions on crack susceptibility of weld crater of the synthesized-weld-metal alloy; (a) Zr addition, (b) Ti or Ti+B addition.

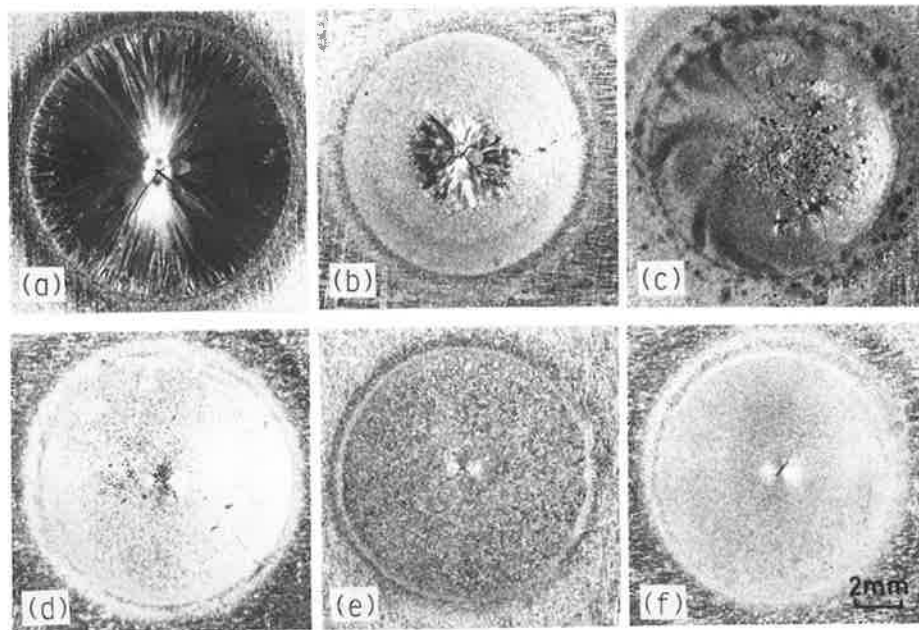

Fig. 3 Macrostructures of the surface of weld crater; (a) 0.1%Zr, (b) 0.24%Zr and (c) 0.36%Zr on Al₂Zn₃Mg, (d) 0.14%Ti, (e) 0.07%Ti+B and (f) 0.49%Ti+B on Al₂Zn₃Mg0.1Zr base alloy.

obtained by more additions of Ti or Ti+B than 0.14% or 0.07%, respectively. More additions didn't show the further more decrease in crack susceptibility. Much addition of Ti+B, 0.49%, inversely increased the crack susceptibility in some extent.

Judging from these results, it is considered that Ti+B is the most favorable element to reduce the crack susceptibility in weld crater. Ti followed after Ti+B, and Zr was less effective in comparison with others.

Figure 3 shows the typical macrostructures of weld crater surface. (a), (b) and (c) in Fig. 3 shows weld of 0.1%Zr (SWM alloy), 0.24%Zr and 0.36%Zr contained alloys. Alloy contained 0.1%Zr shows coarse columnar structures showing elongated cracks occurred in grain boundary. These coarse structures were changed to be fine equiaxed grains at more addition than 0.24%Zr, though columnar grains were remained yet at central part of a weld crater and in this alloy cracking occurred was restricted within this coarse structural part and not extended to the surrounding fine-equiaxed grains. (d), (e) and (f) in Fig. 3 shows weld craters of SWM alloy containing 0.14% Ti, 0.07% and 0.49%Ti+B, respectively. The macrostructures consisted of well-refined equiaxed grains in each alloy in comparison with SWM alloy (a) and only small cracking was observed in shrinkage cavity.

From these macrostructural observations, it is considered that the crater cracking susceptibility of SWM alloy was closely related to grain refinement effect of these additional elements.

(2) Addition by combination of two elements

The coexisting effect of Ti+B together with Zr or Ti on weld crater cracking was also examined.

Figure 4 shows Zr addition on crater cracking of Zr free SWM alloy containing 0.02%Ti+B in advance in comparison with Ti+B free base alloy showing by broken line. Macrostructural change caused by the addition of Zr is also shown in Fig. 5.

A weld crater of Zr free SWM alloy was free from

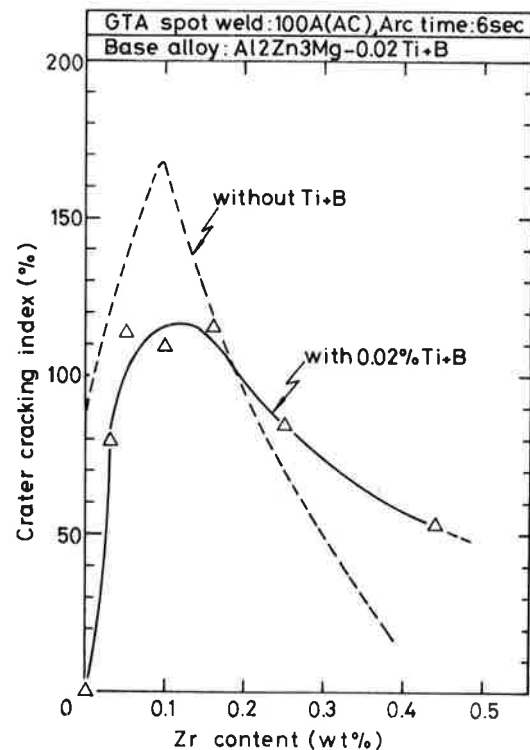

Fig. 4 Effect of Zr addition on crack susceptibility of weld crater of Al₂Zn₃Mg base alloy with 0.02%Ti+B in comparison with those without Ti+B.

cracking due to the grain refining effect of Ti+B as shown in Fig. 5(a). The addition of small amount of Zr up to about 0.1%, however, drastically increased the crater cracking index because of coarsening of grain structures as shown in Fig. 5(b). With the addition of Zr more than 0.25%, crater cracking index again decreased as the decrease in grain size due to the grain refining effect of Zr (Fig. 5(c)), though crater cracking index was larger than that of Ti+B free base alloy in comparison with the same Zr content.

Consequently, it is made clear that the beneficial effects of Zr and Ti+B to reduce the crater cracking was cancelled away with coexistence of these two elements.

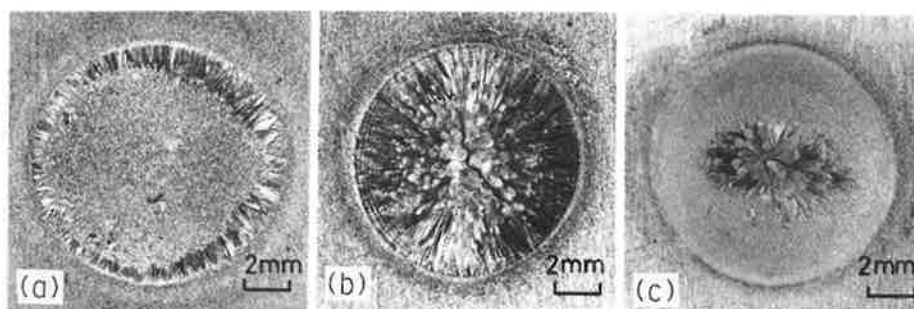

Fig. 5 Macrostructures of the surface of weld crater of Al₂Zn₃Mg base alloy containing 0.02%Ti+B without Zr (a), with 0.03%Zr (b) and 0.25%Zr (c).

Figure 6 shows the effect of small amount of Ti on the weld crater cracking of SWM alloy containing 0.02% and 0.05% Ti+B. Additional Ti addition of 0.1 to 0.2% was beneficial to reduce the weld crater cracking, though much more addition of about 0.5%Ti slightly increased the cracking.

This is due to the grain refining effect of additional Ti as shown in Fig. 7(a), (b) and (c) showing the macrostructures on the surface of weld crater of the SWM alloy containing 0.02%Ti+B, and with additional Ti of 0.05% and 0.1%, respectively.

Judging from these results related to weld crater cracking, it was considered that effects of these additional elements on weld crater cracking was due mainly to their grain refining effect, which was also observed in ring-casting cracking test¹. Therefore, this also draws the next conclusion that effect of additional element on weld crater cracking can be estimated by means of ring-casting cracking test.

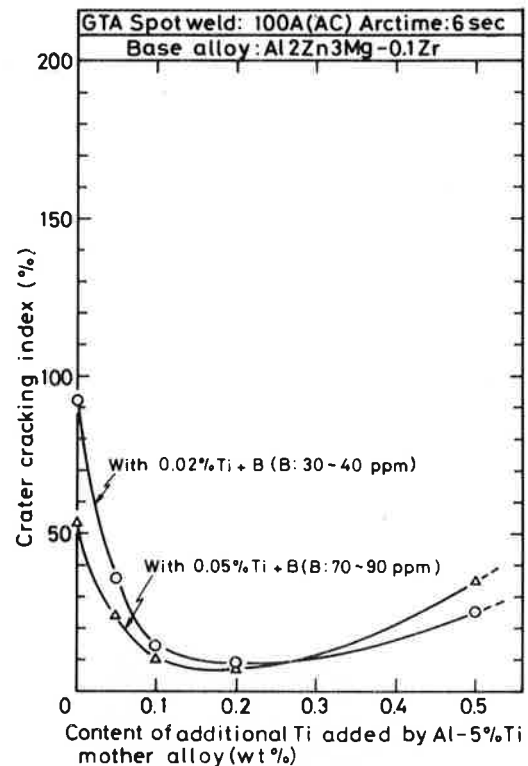

Fig. 6 Effect of additional Ti addition on crack susceptibility of weld crater of Al2Zn3Mg0.1Zr base alloy with 0.02% and 0.05% Ti+B.

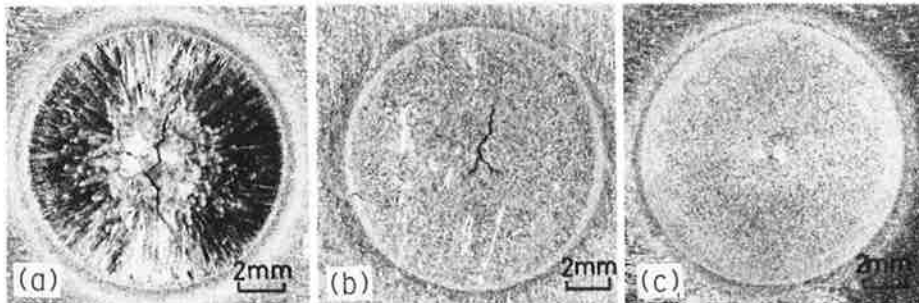

Fig. 7 Macrostructures of the surface of weld crater of Al2Zn3Mg0.1Zr base alloy containing 0.02%Ti+B without additional Ti (a), with 0.05% (b) and 0.1% additional Ti (c).

3.2 Susceptibility of weld bead cracking

At first, effects of individual addition of Zr, Ti or Ti+B on weld bead cracking were examined by Houldcroft-type cracking test. Test results are shown in Fig. 8(a), (b) and (c) for Zr addition on the Zr free SWM alloy, and for Ti or Ti+B on the SWM alloy containing 0.1%Zr, respectively. All cracking-test data were plotted in these figures.

In case of Zr addition, remarkable decrease in weld bead cracking began to appear at more Zr addition than 0.24%. In this Zr content, however, beneficial effect of

Zr was not enough and 0.36%Zr addition was required to reduce the weld bead cracking to much low value enough in this experiment.

Figure 9 shows the macrostructures on weld bead surface. Coarse columnar grain structure was observed in weld metal of the SWM alloy (a), which contained about 0.1%Zr, showing the cracking occurred along the grain boundaries of these columnar grains.

Grain refinement of weld bead began to be observed at 0.24%Zr showing coexistence of fine equiaxed and columnar grains (b), and at 0.36%Zr weld bead structure

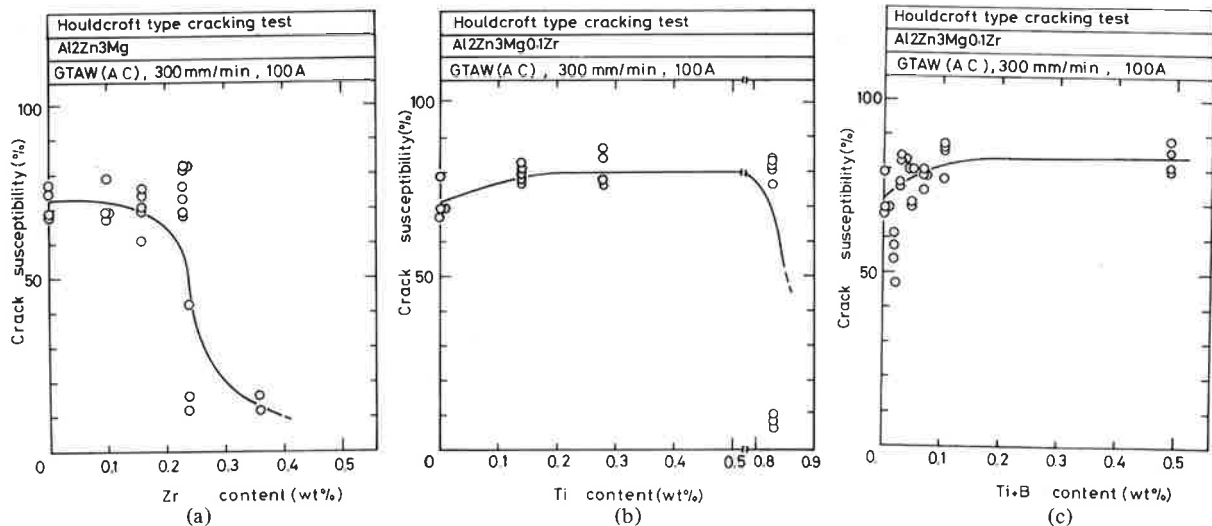

Fig. 8 Effects of Zr, Ti or Ti+B additions on crack susceptibility of weld bead; (a) Zr addition on Al₂Zn₃Mg base alloy, (b) Ti and (c) Ti+B additions on Al₂Zn₃Mg0.1Zr base alloy.

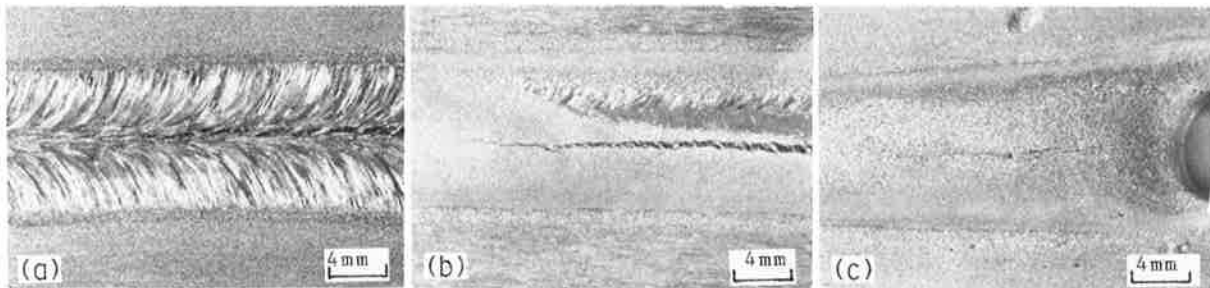

Fig. 9 Macrostructures of the surface of weld bead of Al₂Zn₃Mg base alloy with (a) 0.1%Zr, (b) 0.24%Zr and (c) 0.36%Zr.

consisted of completely fine equiaxed grains only and in this case weld bead cracking was the least.

The close relationship between grain refining and weld bead cracking is more clearly seen in Fig. 10 which shows the appearance and macrostructures of weld bead of the SWM alloy contained 0.24%Zr. In the case of (a) in Fig. 10, a full weld bead consisted of fine equiaxed grains and only small cracking was observed at weld starting zone. On the contrary, in case of (b), macrostructure of weld bead consisted of columnar grains in central zone with fine equiaxed grains near fusion line of weld bead. In this case of grain structure, a large elongated crack was likely to propagate along weld central zone through grain boundaries of columnar grains from weld starting part to almost the end part of welding near weld crater in spite of the same Zr content in (a). These results show that the beneficial effect of Zr addition was closely connected with grain refinement of weld bead.

Ti or Ti+B additions didn't show the beneficial effect to reduce the weld bead cracking as shown in (b) and (c) in Fig. 8 in spite of the fine equiaxed structures of weld bead at more addition of Ti than 0.14% for (a) and (b)

and of Ti+B than 0.07% for (c), (d) and (e) in Fig. 11 showing the macrostructures of weld bead of the SWM alloys. In case of 0.83%Ti addition the decrease in weld bead cracking was partly observed but this effect was much unreliable even with excess addition of Ti from viewpoint of the industrial use. The small deviation of tested data to lower value at 0.02% Ti+B as seen in (c) in Fig. 8 is considered to be the formation of feathery crystal as shown in (c) in Fig. 11.

Figure 12(a), (b) and (c) shows coexisting effect of Zr with 0.02%Ti+B, and Ti with 0.02% and 0.05%Ti+B on weld bead cracking of the SWM alloy respectively. From these figures, only Zr shows the beneficial effect to reduce the weld bead cracking at more addition than 0.25% due to the grain refinement as shown in Fig. 13(d). These tendencies were almost the same observed in the case of Ti+B free base alloy as shown in Fig. 8(a).

Addition of 0.02%Ti+B on Zr free SWM alloy also made a fine-equiaxed structure as shown in Fig. 13(a), but there was no decrease in crack susceptibility observed. Small amount of Zr cancelled this grain refinement effect of Ti+B as shown in Fig. 13(b) and (c). Small amount of

additional Ti addition on the SWM alloys contained 0.02% and 0.05%Ti+B had no beneficial effects to reduce the weld bead cracking or somewhat increased the crack susceptibility in spite of the fine-equiaxed grain structures of weld bead as shown in Fig. 14(a) and (b) for about 0.1%Ti addition with 0.02% and 0.05% Ti+B, respectively in comparison with those in Fig. 11(c) and (d) without additional Ti.

Consequently, as to weld bead cracking it is considered that the beneficial additional element to reduce the crack susceptibility of weld bead was only Zr at more addition than 0.24%, and Ti and Ti+B additions showed almost no beneficial effect in spite of fine-equiaxed grain structure of weld bead. These results also showed that beneficial effect of Zr addition to reduce the susceptibility of solidification cracking was valid in all cases of casted metal, weld crater and weld bead crackings, but beneficial effects of Ti or Ti+B additions were restricted only in the case of casted-metal and weld crater crackings.

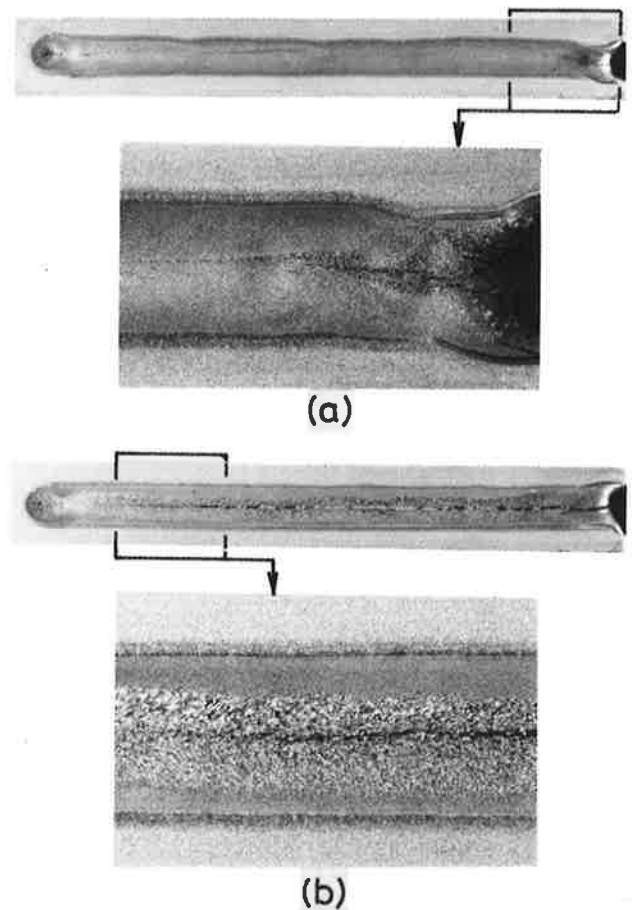

Fig. 10 Macrostructures of the surface of weld bead of Al₂Zn₃Mg containing 0.24%Zr showing (a) fine-equiaxed structure and (b) columnar structure partly with fine-equiaxed structure near fusion boundary.

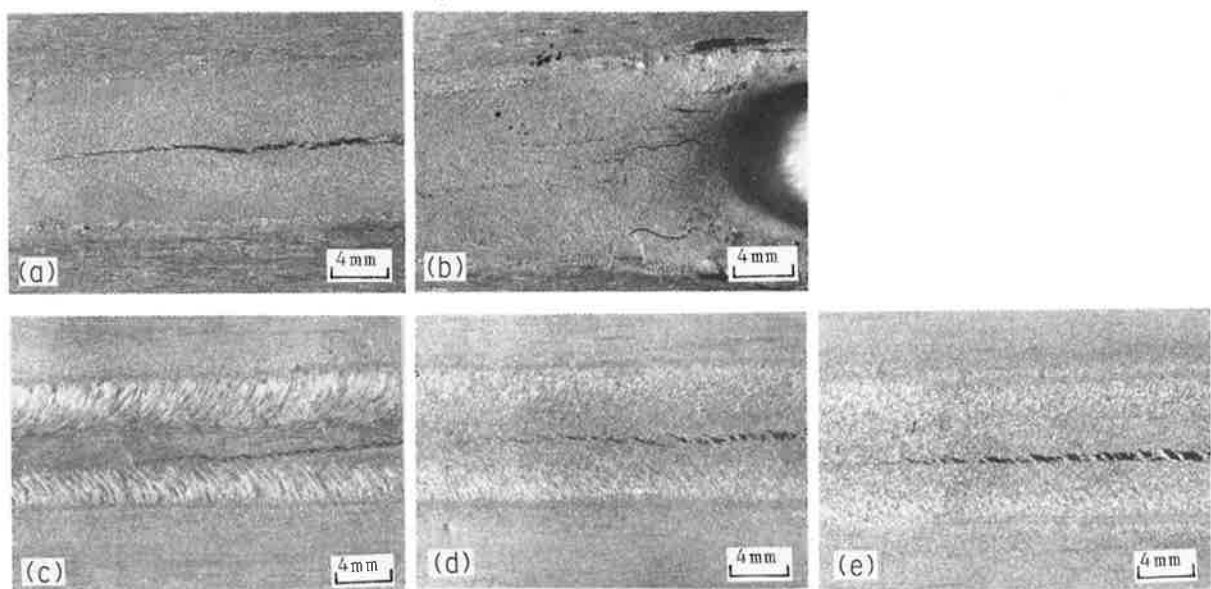

Fig. 11 Macrostructures of the surface of weld bead of Al₂Zn₃Mg-0.1Zr base alloy with (a) 0.14%Ti, (b) 0.83%Ti, (c) 0.02% Ti+B, (d) 0.05%Ti+B and (e) 0.07%Ti+B.

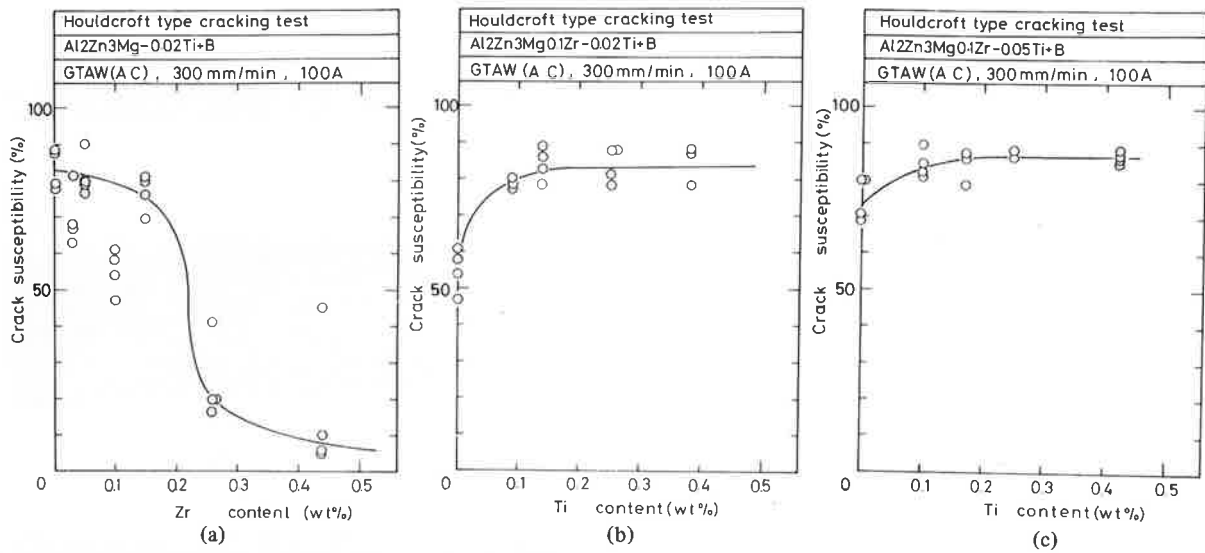

Fig. 12 Effects of combined-addition of Zr or Ti with Ti+B on crack susceptibility of weld bead; (a) Zr addition on Al₂Zn₃Mg base alloy with 0.02%Ti+B, and (b) and (c) Ti addition on Al₂Zn₃Mg0.1Zr base alloy with 0.02% and 0.05%Ti+B respectively.

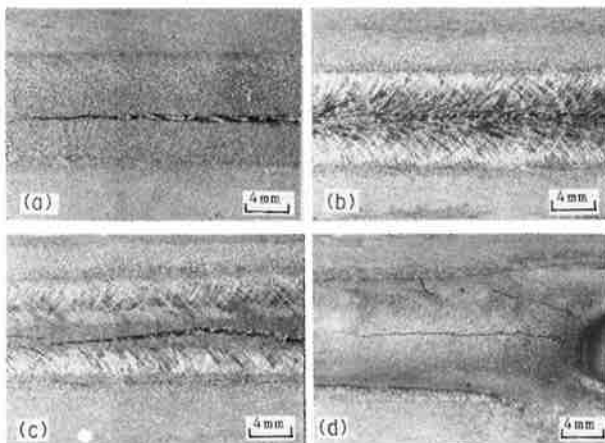

Fig. 13 Macrostructures of the surface of weld bead of Al₂Zn₃Mg base alloy containing 0.02%Ti+B without additional Zr (a), 0.03%Zr (b), 0.16%Zr (c) and 0.25%Zr (d).

3.3 Relation between grain size and crack susceptibility

It was made clear in the previous report¹⁾ by ring casting test that the susceptibility of solidification cracking in casted-metals with and without Zr, Ti and/or Ti+B added depended mainly on the grain size of casted-metal.

The same analysis was done in order to examine the relation between grain size and crack susceptibilities of weld crater and weld bead. Grain-size measurement for each weld crater and weld bead tested were performed by line-intercept method on magnified microphotographs (x50 to x200) showing grain structure around cracked zone. Grain size measured indicates mean diameter of equiaxed grains and mean width of columnar grains.

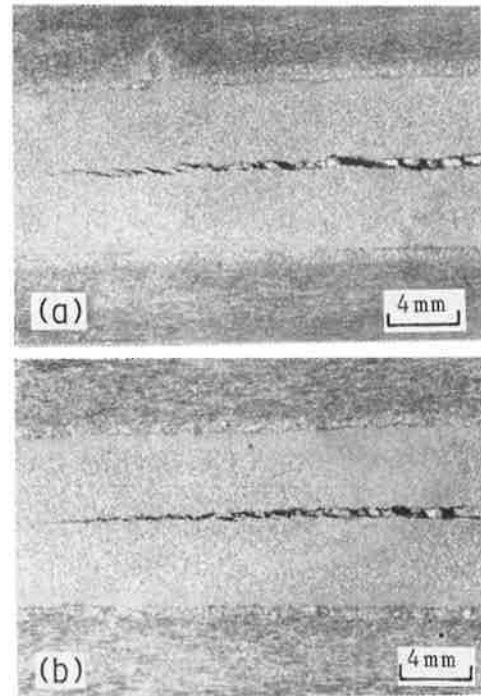

Fig. 14 Macrostructures of the surface of weld bead of Al₂Zn₃Mg 0.1Zr base alloy containing (a) 0.02% and (b) 0.05%Ti+B showing fine-equiaxed structure caused by 0.1% additional Ti addition respectively.

Results are shown in Fig. 15(a) and (b) for weld crater and weld bead, respectively, where open and filled marks indicate the columnar (with coarse equiaxed) and fine equiaxed-grain structures, respectively.

Crater cracking index has a close relation with mean grain size of weld crater as shown in Fig. 15(a). Columnar

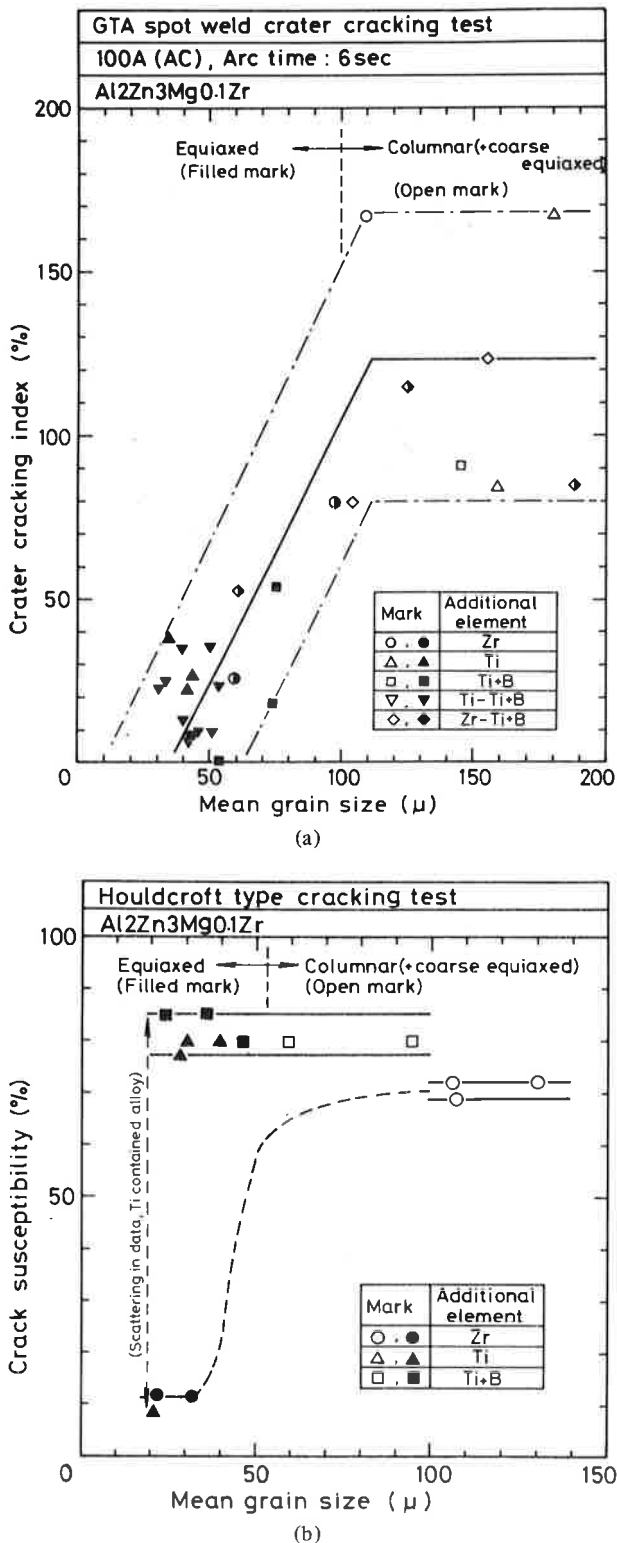

Fig. 15 Relation between mean grain size and crack susceptibility of weld crater (a) and weld bead (b) evaluated by means of GTA weld crater and Houldcroft-type weld bead cracking tests respectively, for Al₂Zn₃Mg_{0.1}Zr synthesized-weld-metal alloy without and with Zr, Ti and Ti+B.

structure showed much higher susceptibility than equiaxed-grain structure, and as the decrease in grain size of equiaxed grains, crater cracking index proportionally decreased almost independently with the kind of additional element. These tendencies are the same as observed in ring-casting test¹⁾.

On the contrary, in case of weld bead cracking evaluated by Houldcroft-type test as shown in Fig. 15(b), crack susceptibility of weld bead was almost constant or even somewhat increased as the increase in grain size in spite of fine-equiaxed grains. It was suddenly decreased discontinuously to very low values for some alloys, when the grain size decreased to 20 to 30 μ in diameter. However, on the other hand, in spite of the same order of grain size of 20 to 30 μ in the above, high crack-susceptibility of weld bead can also be seen.

Consequently, Crack susceptibility of weld bead does not always depend on grain size of weld bead.

With regards to weld crater cracking, it is considered that the strain or deformation required to cause cracking was due mainly to the strain caused by the volume change at the solidification of metal and that caused by the shrinkage of solidified metal in weld crater during solidification. In this strain condition, grain refinement seems to be enough condition to prevent the cracking in weld crater to distribute the strain augmented into many grain boundaries of fine equiaxed grains.

However, as to weld bead cracking occurred in Houldcroft-type cracking test specimen, much strain must be applied on the solidifying weld metal by the deformation of tested specimen itself²⁾ in addition to strain caused by the volume change and shrinkage of metals. Moreover, these total strains possibly concentrated on the weld metal near the tip of the propagating crack along weld center and build up to high strain level. Therefore, to redistribute these build-up strains on grain boundaries, much more fine equiaxed grains are required, and not only grain refinement but also some other possible factors, such as the shape and distribution of remaining liquid in grain boundaries may be related to the susceptibility of weld bead cracking. These subjects will be treated in further work.

3.4 Recommendation for the beneficial additional element for welding filler wire

On the basis of the present work, among Zr, Ti and Ti+B, only Zr can be recommended for the beneficial additional element to welding filler wire in order to prevent the solidification cracking in weld crater and weld bead of 7N01 base alloy by MIG arc welding. As to the beneficial amount of Zr in filler wire, more than 0.25 to

0.3%Zr is required in filler wire to prevent the cracking because more than 0.24%Zr is required to be contained in weld bead in order to prevent the cracking in this experiment and filler wire composition is generally diluted to 50 to 80% by the base metal composition of 7N01 containing about 0.16%Zr.

With regards to Ti addition, which showed partly beneficial effect at 0.83%Ti in weld metal, more than about 1.5%Ti is required at least for filler wire composition. However, it is too much content to make filler wire for MIG arc welding in commercial manufacturing condition.

4. Conclusions

Effects of Zr, Ti and/or Ti+B additions on the crack susceptibilities of weld crater and weld bead of the synthesized-weld-metal Al-2%Zn-3%Mg-0.1%Zr alloy have been evaluated by means of the GTA spot weld crater and Houldcroft-type weld bead cracking tests.

Conclusive remarks obtained in this experiment were as follows;

As to weld crater cracking,

- (1) Zr, Ti or Ti+B additions showed the beneficial effect to reduce the crater cracking with more addition than 0.36%, 0.14% and 0.07%, respectively.
- (2) The crack susceptibility of weld crater depended mainly on the grain size in weld crater. As the decrease in grain size, cracking susceptibility was almost proportionally decreased.
- (3) Small amount of additional Ti addition showed the promoting effect to reduce the crater cracking of weld crater containing Ti+B by promoting the grain refinement of Ti+B addition only.
- (4) Small amount of Zr addition up to about 0.1% onto the base alloy containing Ti+B showed harmful effect to prevent the crater cracking by cancelling the grain refinement effect of Ti+B. More addition than 0.25%Zr, however, showed the beneficial effect to reduce the cracking due to the grain refinement effect of Zr.

As to weld bead cracking,

- (5) Among Zr, Ti and Ti+B, only Zr addition showed the beneficial effect to reduce the crack susceptibility of weld bead with more addition than about 0.24%. This beneficial effect of Zr was mainly due to the grain refinement of weld bead.
- (6) Ti addition showed partly beneficial effect to reduce the weld bead cracking at the addition of 0.83%, though its beneficial effect is much unreliable.
- (7) Ti or Ti+B additions showed the marked effects to grain refinement of weld bead with more addition than 0.14% and 0.07%, respectively. In case of Zr, more than 0.24% was required to realize the fine-equiaxed grains, though grain refinement was somewhat unstable with this content.
- (8) There were no remarkable relationships between crack susceptibility and grain size of weld bead. However, it is considered that grain refinement of weld bead is undoubtedly necessary to reduce bead-crack susceptibility, though it is not a sufficient condition.
- (9) From the above experiment the use of 5356 filler wire containing about 0.3%Zr will be required to eliminate both crackings of weld bead and crater for MIG welding of 7N01 alloy.

Acknowledgements

The authors would like to express our thanks to Mr. Yoshiaki Shimokusu, Graduate student of Osaka Univ., Mr. Akira Matsushita and Mr. Sachio Takeuchi, formerly students of KINKI Univ. and Mr. Masahiro Maeda, Student of Osaka Institute of Technology for their helpful assistances in this study.

References

- 1) F. Matsuda et al.: Trans. JWRI, 12 (1983) 1, 81-87.
- 2) F. Matsuda et al.: Trans. JWRI, 9 (1980) 2, 83-93.